

THIS DRAWING IS UNPUBLISHED. RELEASED FOR PUBLICATION, 19 .  
 © COPYRIGHT 19 BY AMP INCORPORATED. ALL INTERNATIONAL RIGHTS RESERVED.

LOC	DIST	P	F	REVISIONS				
AF	50			ZONE	LTR	DESCRIPTION	DATE	APPD
					N	REVISED PER 063A-0271-02	19AUG02	MF/DD

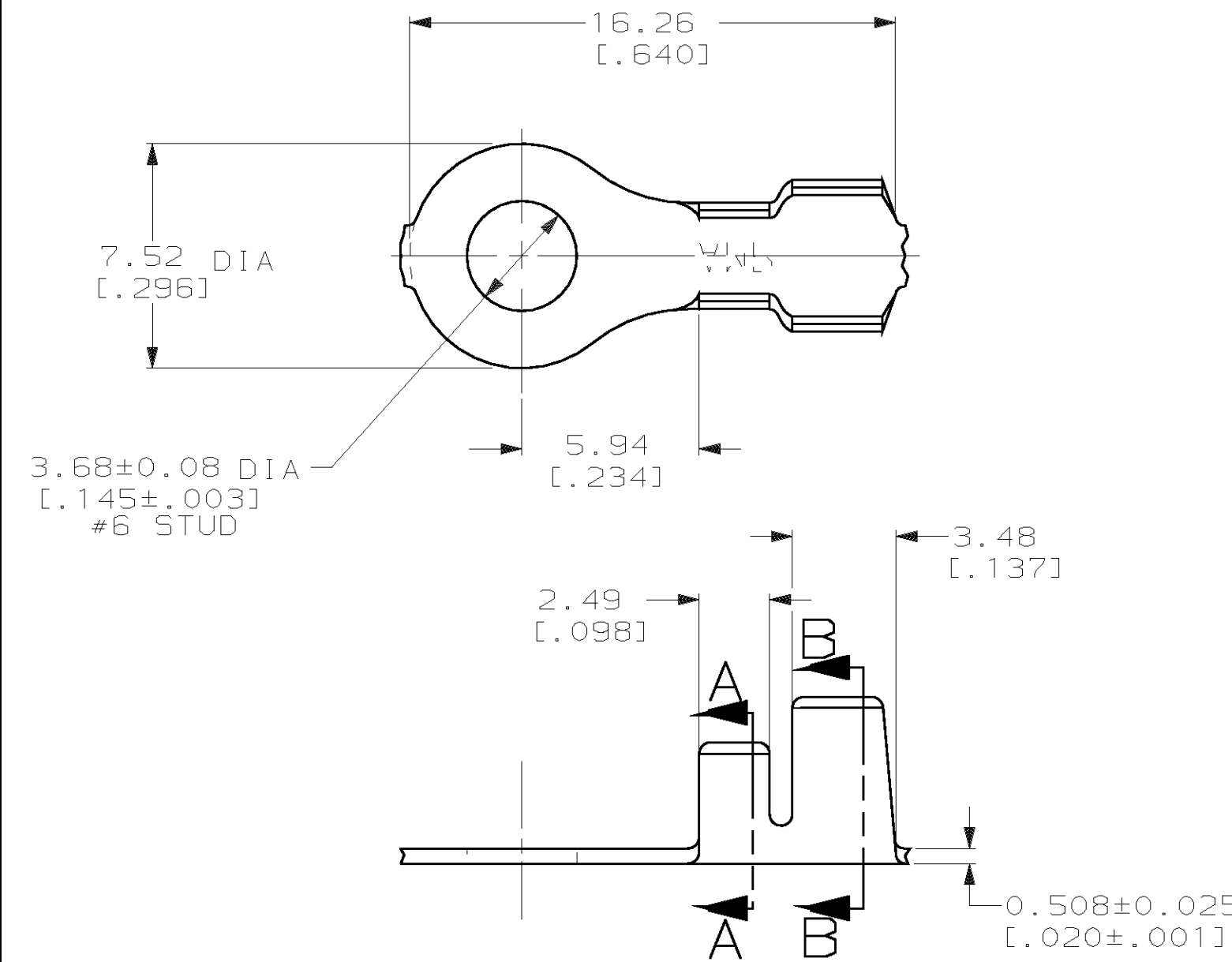

- 1 CONTINUOUS STRIP ON REEL.
- 2 0.00381 [0.000150] MIN NICKEL PLATE.

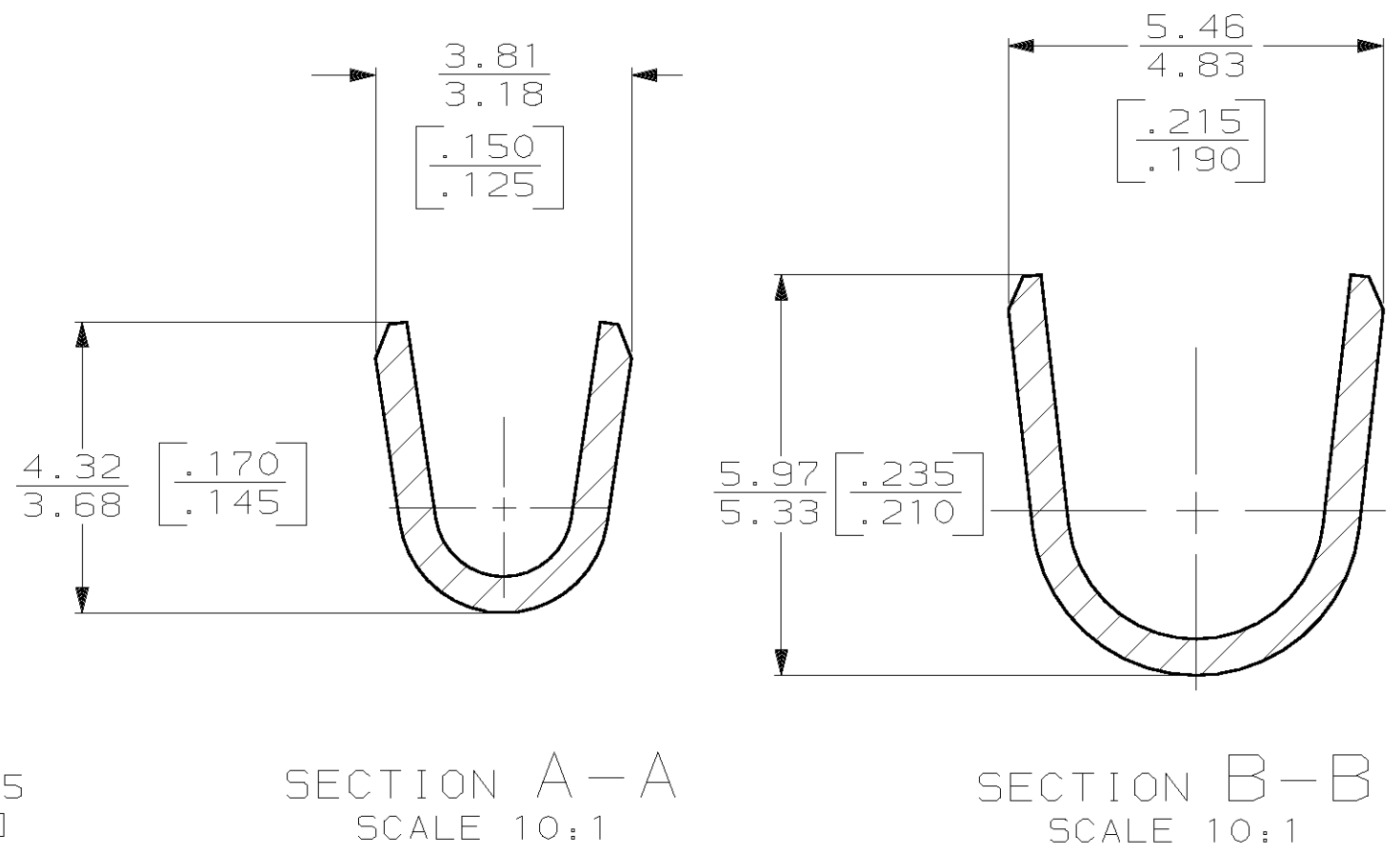

**METRIC**

FINISH	MATERIAL	INSULATION RANGE	WIRE RANGE	PART NO
—	#3 HARD STEEL 082 BRASS	3.05-4.32 DIA [0.120-.170]	0.8-2.0mm [18-14] AWG	41558-1 41558

F OR 0	4.57 [0.180]	4.06 [0.160]	F	3.05 [0.120]	2.03 [0.080]	2.0mm [14]
TYPE	WIDTH	STRIP LENGTH ±0.38 [±0.015]	TYPE	WIDTH	HEIGHT ±0.051 [E.002]	WIRE
INSUL BARREL CRIMP			WIRE BARREL CRIMP			

DO NOT SCALE PRINT. UNLESS SPECIFIED DIMENSIONS IN mm [INCHES] TOLERANCES ON:	DR 7/22/91 P FORTNEY
2 PLC DEC ± 0.25 [0.010]	CHK 8/8/91 MS FEHER
3 PLC DEC ± -	APPD 8/12/91 G YETTER
ANGLES ± -	APPD 8/12/91 R WEAVILL
MATERIAL	PRODUCT SPEC
SEE TABLE	-
FINISH	APPLICATION SPEC
SEE TABLE	-
	WEIGHT -

AMP Incorporated Harrisburg, PA 17105-3608		
NAME		
RING		
SIZE	CAGE CODE	DRAWING NO
B	00779	41558
SCALE	SHEET	
5:1	1 OF 1	